

FITZROY BALL BEARING DOOR TRACKS

ALLOY LIGHT A100S
ALLOY MEDIUM A500S

Hand Operated Synchronised
 Bi-Parting Track

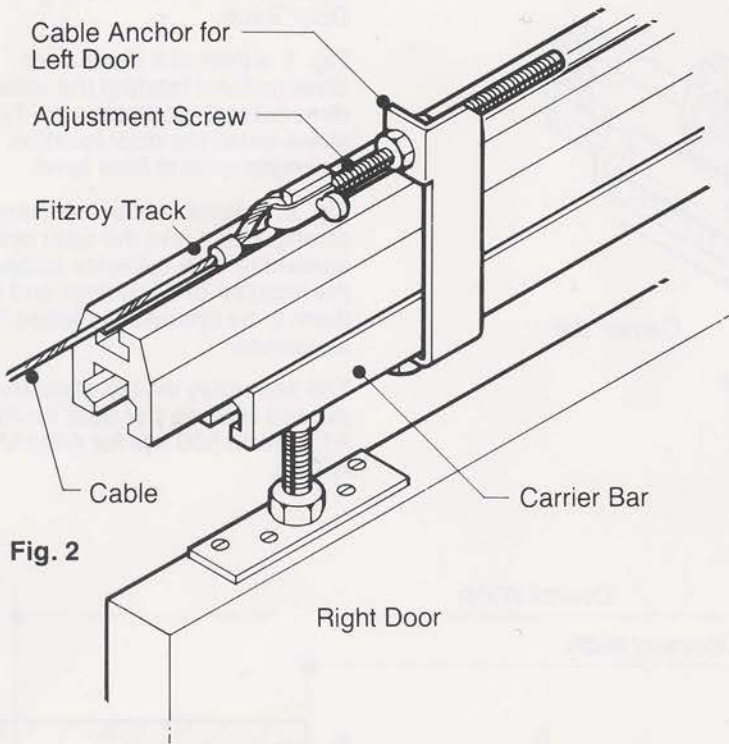

Fig. 2

Set out on this page is a Hand Operated Bi-Parting Door System using the Alloy Medium "Fitzroy" Door Track.

Fig. 1A: an elevation of the "Fitzroy" Door Track System showing the various components with the doors closed
 Fig. 1B: the same track with the doors open.

Fig. 2: the "Fitzroy" Track with details of the door fixing and cable anchor arrangements.

The assembly weight should not exceed 100 kgs per door for Alloy Light A100bp and 500 kgs for Alloy Medium A500bp.

CHARLES MARSHALL PTY. LTD

ACN 004 107 411

451 Burnley St., Richmond,
 Victoria. 3121. Australia

Phone: (03) 9429 9044.

Fax: (03) 9428 0238.

Distributed by:

Fig. 1A

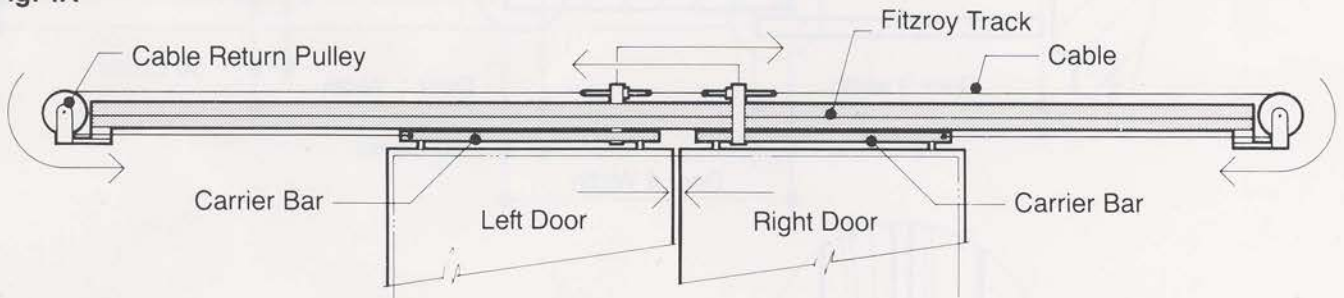

Fig. 1B

