

REVISION DETAIL		
DESCRIPTION	DATE	APPROVED

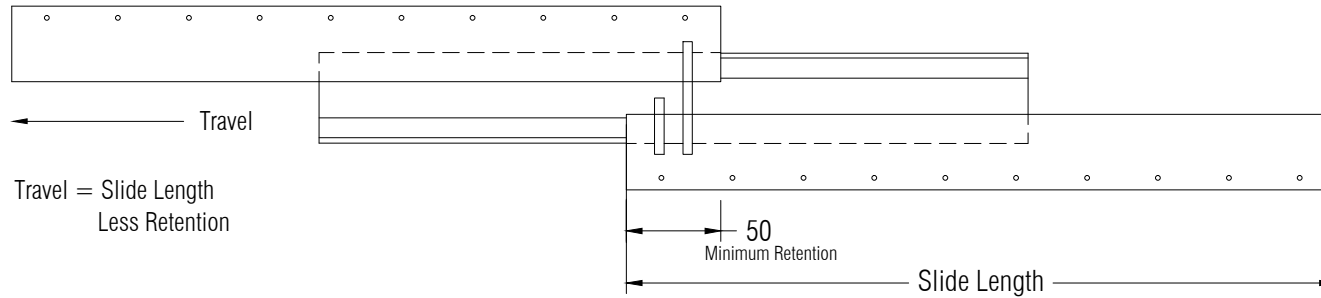
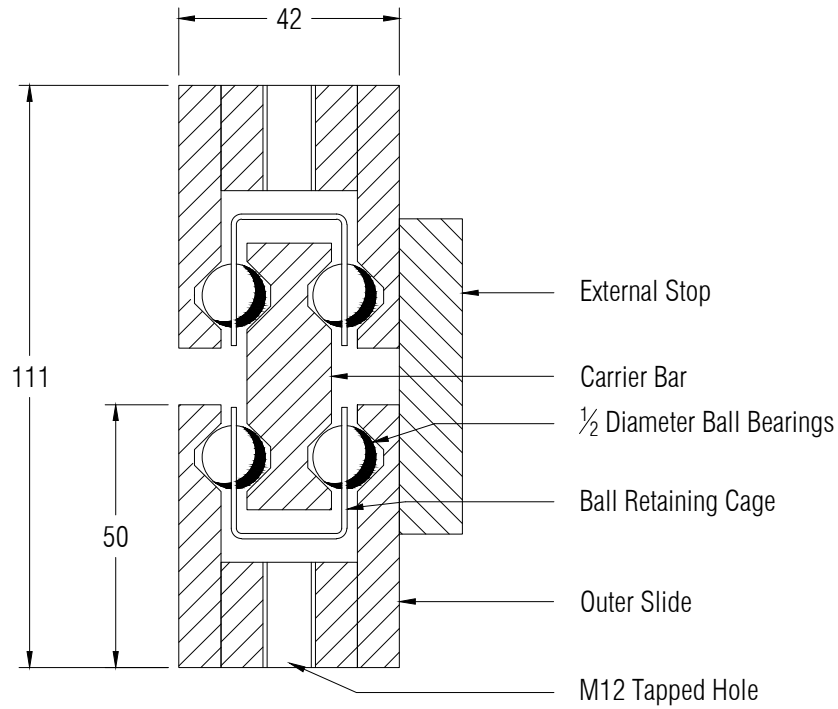

**CHARLES MARSHALL PTY. LTD.**  
 451 BURNLEY ST. RICHMOND. VIC. 3121 PH: 03 9429 9044 FAX: 03 9428 0238  
 3rd ANGLE PROJECTION DO NOT SCALE  
 TITLE: S500WD STEEL MEDIUM FITZROY HEAVY DUTY WITHDRAWAL UNIT

TOLERANCE: UNLESS NOTED, M/C & HOLE CENTRES TO .5. ANGLES +/- 0 30 M/C WHERE SHOWN SYMBOLS TO AS1100  
 NOTE: THIS DRAWING AND DESIGN IS THE PROPERTY OF CHARLES MARSHALL. AND MUST  
 NOT BE COPIED, LOANED OR OTHERWISE USED WITHOUT THEIR EXPRESS PERMISSION OR LICENCE IN WRITING

MAT:	DRAWN: B. Hunter	FINISH:	DATE: 22/09/2021
SCALE:	APPROVED:	PART. NO. S500WD	SHT OF