

## A500 ALLOY MEDIUM FITZROY® BALL BEARING DOOR TRACKS

"FITZROY" Reg Trade Name No. 226500  
 WEIGHT CAPACITY - 500kg

PROTOTYPE TESTED TO 250 000 OPERATIONS UNDER FULL LOAD

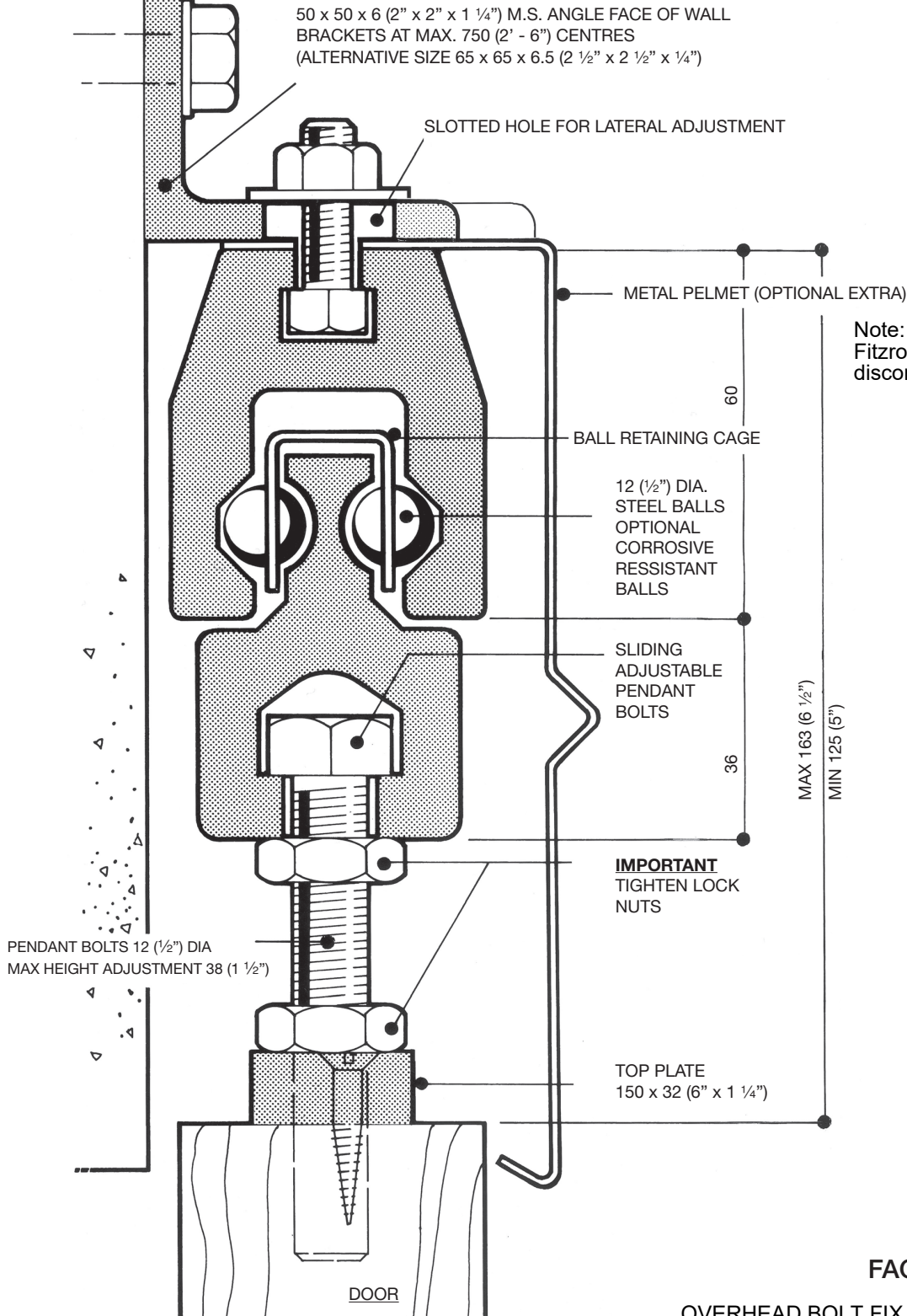

Note: Pelmet to be by others. Fitzroy Tracks pelmet discontinued - unavailable.

FACE OF WALL FIXING  
 SCALE: FULL SIZE  
 OVERHEAD BOLT FIX (Disregard FOW bracket)

## A500 ALLOY MEDIUM FITZROY®

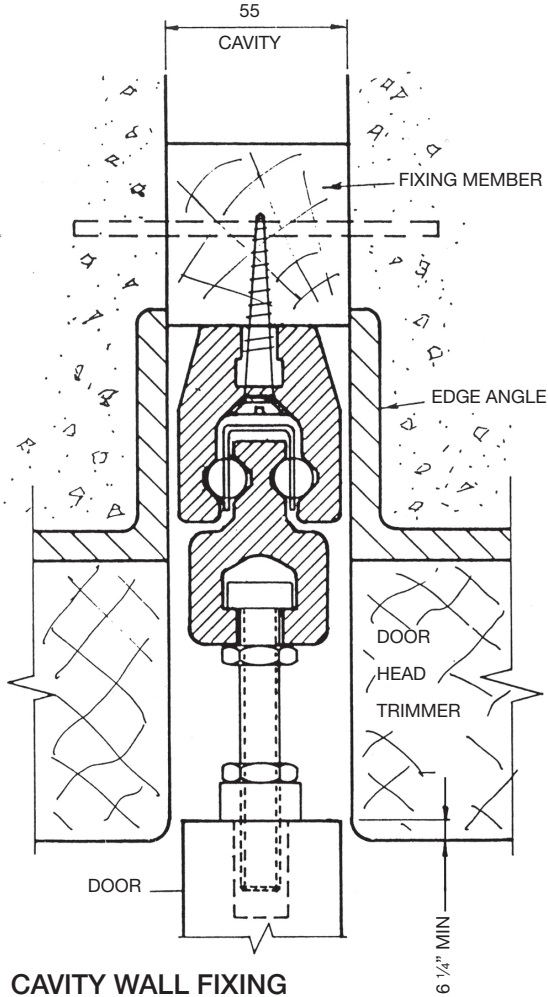

**CAVITY WALL FIXING**  
 SCALE: HALF FULL SIZE

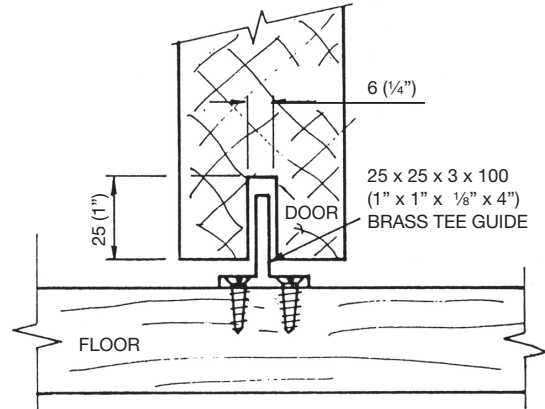
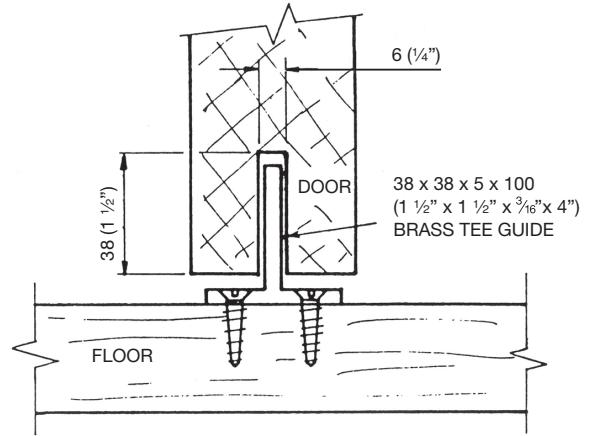

**DOOR BASE GUIDES**  
 SCALE: HALF FULL SIZE

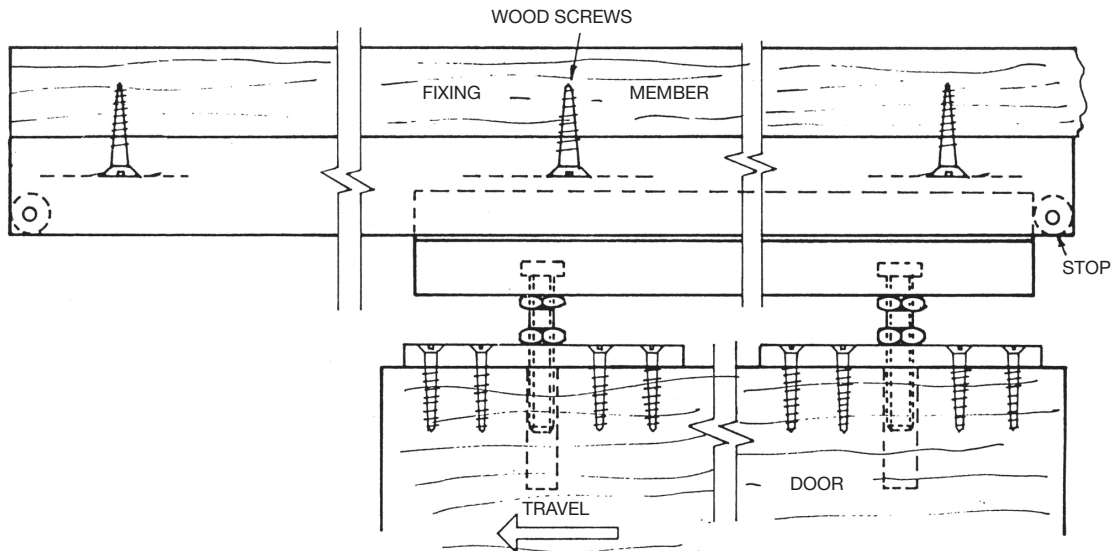

**ELEVATION CAVITY FIXING**  
 SCALE: QUARTER FULL SIZE

## FITZROY® BALL BEARING DOOR TRACKS

### ALLOY MEDIUM A 500 Weight Capacity - 500kgs

SCALE: FULL SIZE

Fig. 3

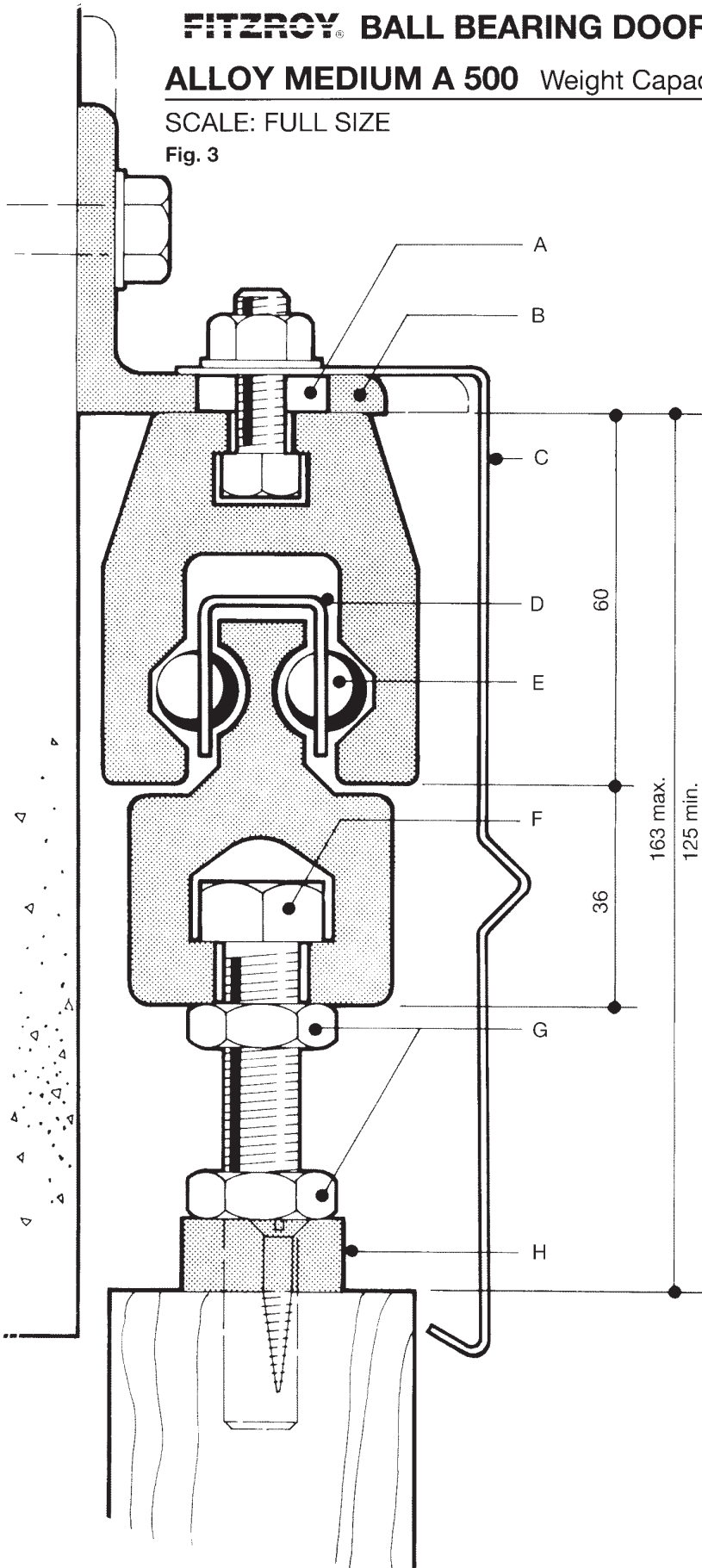

#### ENGINEERING DETAILS

Set out on this page is a full size cross sectional view of a typical face of wall fixing using the "Fitzroy" Alloy Medium Track, No. A500.

The weight capacity for the track is 500Kg. All dimensions are in millimeters.

- A Slotted hole for lateral adjustment
- B 50 x 50 x 6 Mild Steel angle face of wall brackets at max. 750 centres (alternative size 64 x 64 x 6)
- C Metal pelmet (optional)
- D Ball retaining cage
- E 12 dia. balls
- F Sliding adjustable pendant bolts  
Pendant bolts 12 dia.
- G **IMPORTANT** tighten lock nuts
- H Top plate 150 x 30 x 12

#### SPECIFICATION INFORMATION

In order to obtain the correct "Fitzroy" Track System for your project, the following information must be supplied by you:

- Door width
- Door opening width
- Door construction, weight and thickness
- Wall construction
- Whether face of wall, cavity wall or other fixing

Fitzroy Tracks Pty Ltd will supply the correct length track, hanging brackets, top plates, base guide and fixing specification to suit your particular application.

#### ARCHITECTURAL SPECIFICATION

To fully specify the "Fitzroy" Track set out the following.

The "Fitzroy" Ball Bearing Door Track, Alloy Medium, A500 manufactured by Fitzroy Tracks Pty Ltd. shall be used for all doors up to 500Kg per door. The track shall be extruded aluminium with fully enclosed multi ball carrying cage. All face of wall brackets, lateral adjustment, pendant bolts and door top plates will be supplied by Fitzroy Tracks Pty Ltd.

Fig. 1

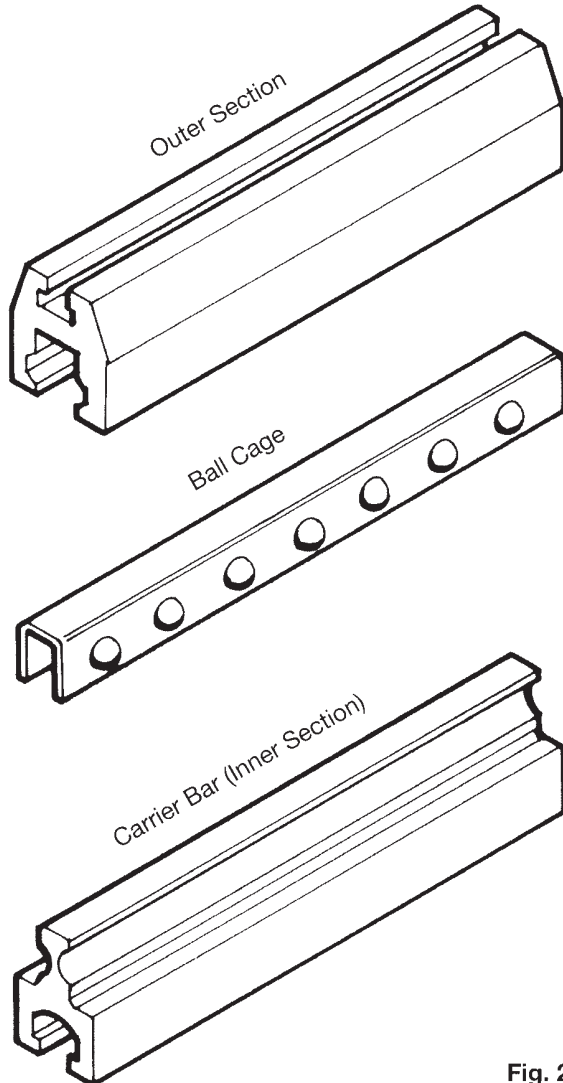
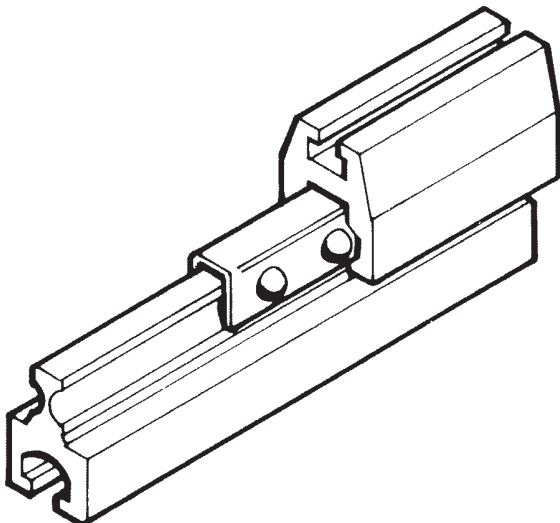

Fig. 2



## DESCRIPTION

Ball bearings, evenly spaced within a cage roll in close tolerance grooves within a track, providing easy, smooth movement. The many ball bearings within the track ensure that the door weight is evenly distributed and balanced, greatly reducing starting and rolling resistance.

The “Fitzroy” Track System is available in sizes to suit every application from kitchen drawers to power station doors. The track consists of three basic components, an outer section, a ball retaining cage and a carrier bar (Fig. 1 & 2).

Both the outer section and the carrier bar are extruded to exacting tolerances from a hard alloy aluminium to preserve the size and shape of the internal ball grooves.

The outer section is usually made to the combined length of door width and door travel. Fixing bolts fit into the top extruded groove at adjustable centres.

The carrier bar is usually less in length than the width of the door and fixed by pendant bolts to the door.

The ball retaining cage is a steel channel punched with holes and lips at regular intervals. The cage acts purely as a ball retainer and spacer and extends over two-thirds of the outer section length. Door weight is spread evenly over many steel balls at any one time.

An independent test authority has reported that track and ball wear have been almost eliminated. The exhaustive tests were summarised in a report which concluded that “. . . the wear rate was so low it was impossible to estimate the life of the track.

The unique design of the “Fitzroy” Track enables two tracks to be used in parallel without jamming or binding, as is often the case with wheel track systems.

“Fitzroy” Track Systems are normally manufactured from aluminium alloy or steel but for special applications brass tracks can be produced.

Bronze anodising is the standard finish, other finishes are available.

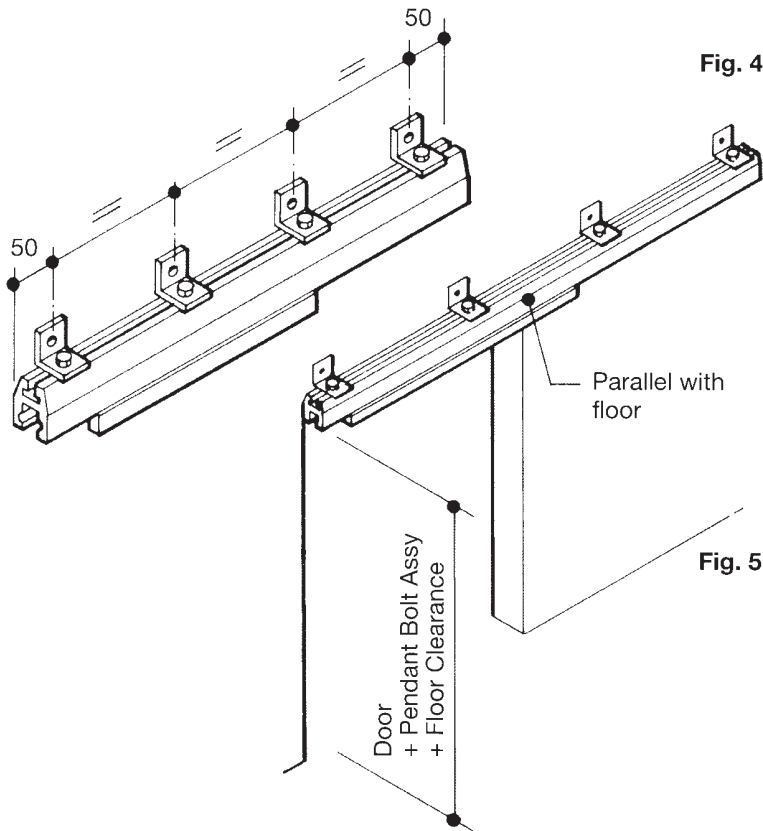

Fig. 4

Fig. 5

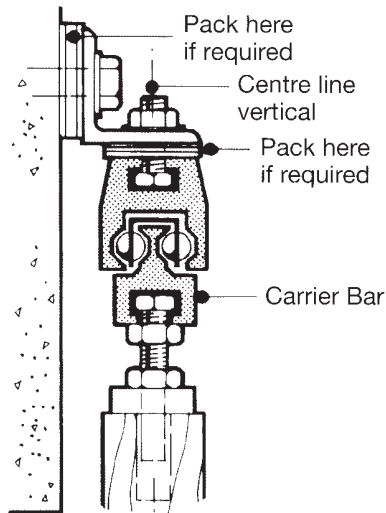

Fig. 6

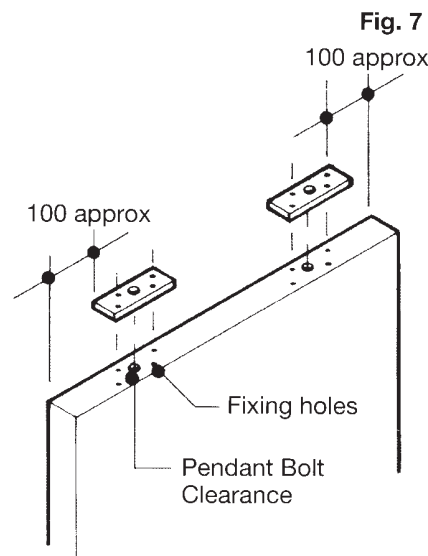

Fig. 7

## ASSEMBLY INSTRUCTIONS

### Face of Wall Fixing Method

Set out below is a typical face of wall fixing procedure. Due to specific job requirements, these instructions may require modification.

1. Check components are correct for specified fixings.
2. Equi-space mounting brackets along outer section, positioning outer brackets 50mm in from each end (Fig. 4)
3. Offer track assembly up to wall. Position in line with the closed end of the door aperture and parallel to floor. Height above floor should be door height plus pendant bolt assembly at mid position, plus floor clearance. Allow for floor covering thickness (Fig. 5)

4. Locate fixing hole centres on wall and drill for specified wall anchor fixing.
5. Re-position track against wall, packing it out if necessary. **ENSURE THAT IT IS PERFECTLY STRAIGHT AND TRUE.** As a check for straightness the ball cage and carrier bar assembly should move completely freely.

Ensure at this stage that the track is positioned with a vertical centreline. Pack if necessary and fix to wall firmly (Fig. 6)

6. On the door, locate positions of top plates (Fig. 7) drill pendant bolt clearance holes 12 diameter, and plate fixing pilot holes. Fix plates firmly to the door with the specified fixings.

Machine base guide groove if required (Fig. 8)

7. Screw pendant bolts, each with two off lock nuts into the door top plates. Screw into nearly the maximum travel to ensure floor clearance.
8. Slide the pendant bolt and door assembly into the carrier bar extrusion. Position the door along the carrier bar. Adjust for height, check clearance and travel. **Lock nut firmly** in position. (Fig. 9)
9. Attach base guide and pelmet if required.

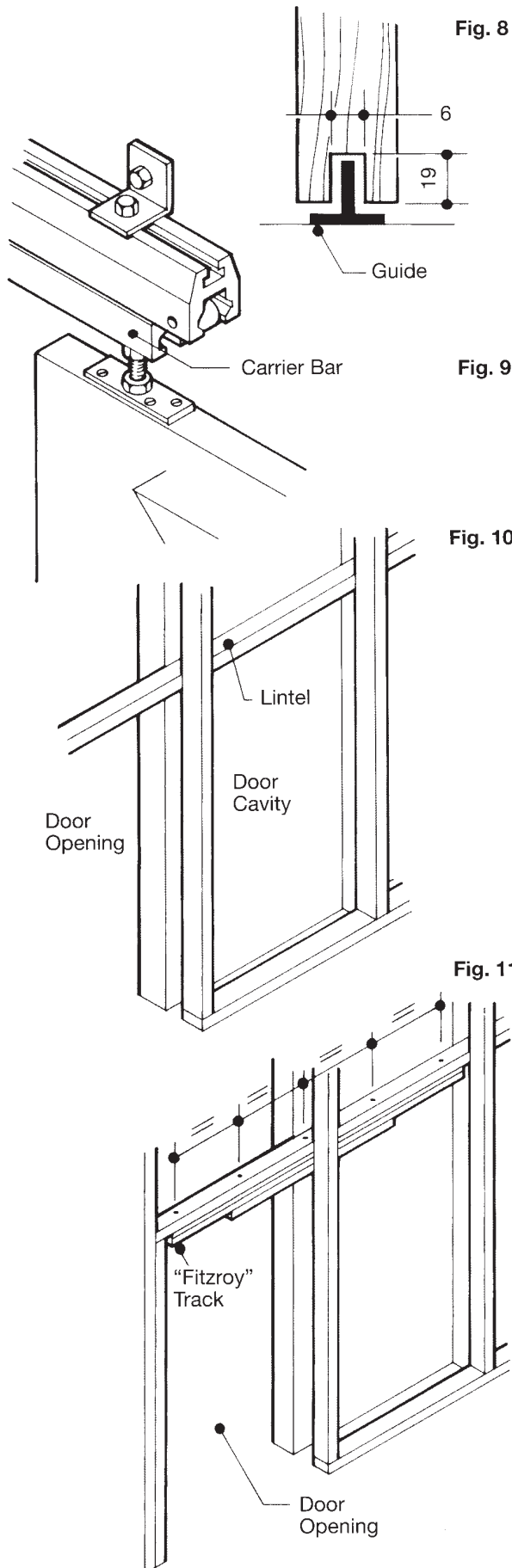

### Cavity Wall Fixing Method

1. Check components are correct for specified fixings.  
 For cavity wall installations access must be gained from one side of the door cavity for the fixing of the "Fitzroy" Track to the doorway lintel (Fig. 10).
2. Position the "Fitzroy" Track and drill pilot fixing holes into the lintel above the track (Fig. 11)
3. Firmly tighten all fastenings. Ensure that the carrier bar runs freely throughout its whole travel. Ensure also that the track assembly is positioned with its centre line vertical and that it is parallel with the floor. Pack if necessary and retighten fixings.
4. Check the combined door height, track assembly height and floor clearance against the door aperture height. Machine door to correct height if necessary. Locate positions of door top plates (Fig. 7). Drill pendant clearance bolt holes and screw fixing holes. Fix plates firmly to the door with the specified fixings. Machine base guide groove if required (Fig. 8).
5. As per 7 above.
6. As for 8 above.

### IMPORTANT

The carrier bar is long and straight and it must be free to slide in a straight line. If the track is warped, bent or twisted, it will not slide freely.

If the door is not sliding smoothly and freely after ensuring above procedures are satisfactory, check the following:

- Door might be warped and scraping on wall or jamb .
- Floor guide may not be in line with overhead track.
- Door might be scraping on an uneven floor
- Rubble may be caught under and scraping on door.

### FITZROY TRACKS PTY LTD

3 Ramage Street,  
 Bayswater, Victoria, 3153, Australia.  
 Phone: (03) 9429 9044  
[info@fitzroytracks.com.au](mailto:info@fitzroytracks.com.au)  
[www.fitzroytracks.com.au](http://www.fitzroytracks.com.au)

REVISION DETAIL		
DESCRIPTION	DATE	APPROVED

**FACE OF WALL FIXING**

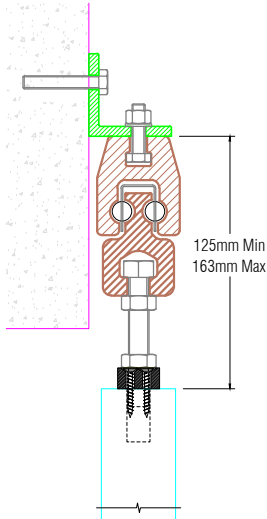

**OVERHEAD BOLT FIXING**

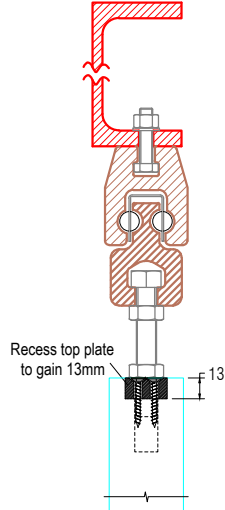

**OVERHEAD SCREW FIXING**

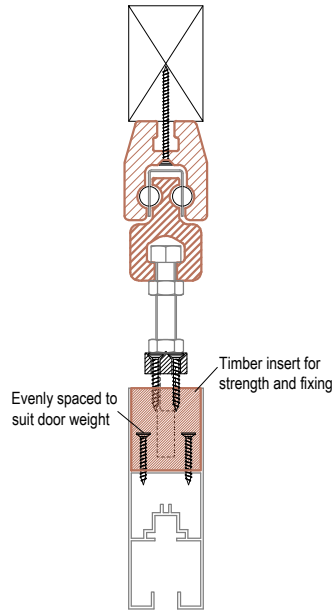

**OVERHEAD SCREW FIXING**

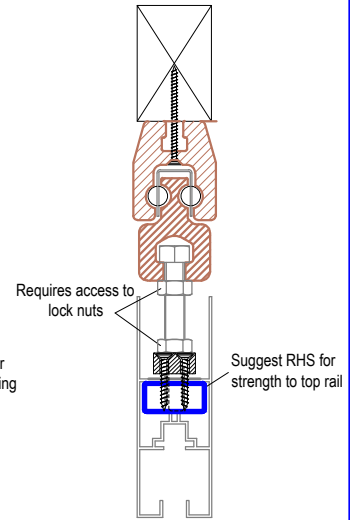

**TIMBER DOOR GUIDE OPTIONS**

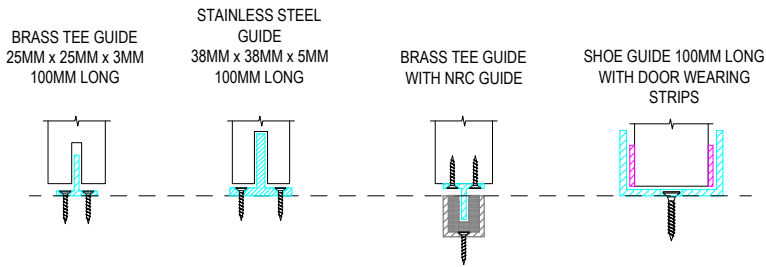

**ALUMINUM DOOR GUIDE OPTIONS**

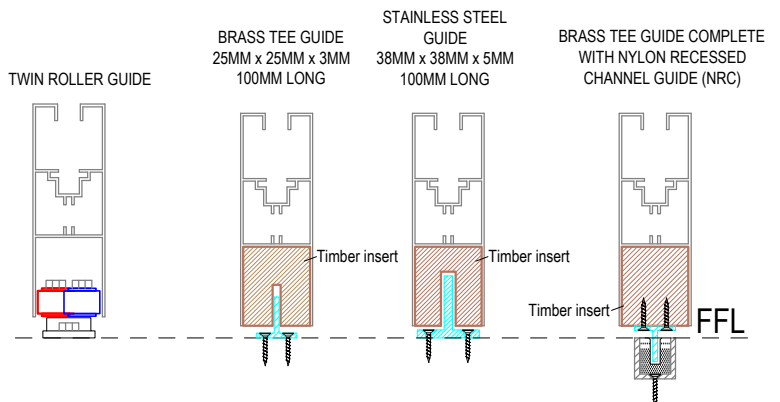

**FITZROY.**  
BALL BEARING SLIDING TRACK SYSTEM

**CHARLES MARSHALL PTY. LTD.**

451 BURNLEY ST. RICHMOND. VIC. 3121 PH: 03 9429 9044 FAX: 03 9428 0238

3rd ANGLE PROJECTION

DO NOT SCALE

TITLE: A500 ALLOY MEDIUM "FITZROY" SLIDING DOOR TRACK SYSTEM

THIS DRAWING AND DESIGN IS THE PROPERTY OF CHARLES MARSHALL PTY LTD AND MUST NOT BE COPIED, LOANED OR OTHERWISE WITHOUT THEIR EXPRESS PERMISSION OR LICENCE IN WRITING

DRAWN: B. Hunter	FINISH:	DATE: 13\02\2019
APPROVED:	PART. NO.	SHT OF







A500\_1a\_2g1.jpg

